

# StarClass Rules and Regulations 2008-2009



<b>DEFINITIONS .....</b>	<b>3</b>
<b>COMPETITION .....</b>	<b>3</b>
Requirements .....	3
Designation of StarClass Competitions .....	3
<b>PARTICIPANTS .....</b>	<b>4</b>
Qualification .....	4
Entry .....	4
<b>OFFICIALS .....</b>	<b>4</b>
<b>EXPENSES .....</b>	<b>5</b>
<b>CONDITIONS OF CONTEST .....</b>	<b>5</b>
StarClass.....	5
All Final System .....	5
Seeding Procedure .....	5
Number of Skaters per Race .....	6
Disqualifications .....	6
Classification and Points scoring .....	6
Doping Control .....	6
Results.....	6
<b>ORGANIZATION .....</b>	<b>6</b>
<b>COORDINATION.....</b>	<b>6</b>
Coordination Group.....	6
Communication .....	7
<b>DANUBIA SERIES.....</b>	<b>7</b>
<b>STARCLASS/DANUBIA FINAL .....</b>	<b>7</b>
Hotel Costs.....	7
ISU Development Program .....	7
<b>SEASON 2008/2009.....</b>	<b>8</b>
Competitions .....	8
Coordination Group.....	8
<b>DRAFT ANNOUNCEMENT FOR ALL STAR CLASS COMPETITIONS .....</b>	<b>9</b>
Entries .....	9
Preliminary Entry.....	9
Final Entry .....	9
Entry Fee.....	9
Conditions of Contest.....	10
Categories .....	10
Distances .....	10
General Programme.....	10
Board and Lodging.....	10
Track .....	10
Award of Prizes .....	11
Medical Assistance .....	11
Medical Insurance .....	11
Liability .....	11
Address Organizing Committee .....	11

## Definitions

'StarClass' is a separate category of participants, both ladies and men, at International Short Track Speed Skating Competitions for which the participants qualify by a time limit.

'StarClass' Juniors are category by age, according to ISU Regulations, for which the participants qualify by a time-limit. ([see time limit table on page 4](#))

A 'StarClass' Competition is an open International Competition in Short Track Speed Skating in accordance with all Regulations of the International Skating Union, which has been designated by Western European ISU Members as such during the annual planning meeting of European Members of the ISU.

The 'All Finals System' is a Qualification Process through which all participants qualify from their first preliminary round up to a Final.

The Annual Planning Meeting is the Meeting of Representatives of European Members of the ISU whose main purpose is the planning of international Club Competitions.

StarClass Coordination Group is a group of 4 people as decided by the Western European ISU Members at the annual meeting who are responsible to coordinate the 'StarClass' series of competitions who monitor and decide upon the entries in liaison with the organisers, they also adjudicate over any questions or queries that may arise.

## Competition

### **Requirements**

In order to be designated as a StarClass Competition the organisers must agree that the respective international competition will be held in accordance with these agreements, made by Western European Members of the ISU on the occasion of their Annual Planning Meeting.

The 2008 Rules of the International Skating Union must be observed and the List of Officials must comply with later specified criteria. The distances must be in conformity with the Conditions of Contest as laid down in these agreements. For the progression an 'All Finals System' is mandatory.

All Organisers must use the StarClass Logo on all printed matter.

A Medical Doctor and paramedic personnel must be present during the Competition. An Ambulance must be on site standby if an acceptable response time cannot be guaranteed. In this respect an ambulance is a car which has life-saving equipment and is suitable for the transport of injured people.

The Medical Staff must have equipment to deal with Cut Resistant Uniforms.

### **Validity of StarClass**

In the case of 6, or less, entries e.g. actual participants, in a category in the first qualifying round of the first distance, then this category will not compete as such and the entered participants will be added to the next higher category.

### **Designation of StarClass Competitions**

The organisers of the international competitions, designated as StarClass Competitions, must have proven experience and their Competitions must have been held for a number of years and/or have been proposed by the Coordination Group.

During the Annual Planning Meeting these competitions are designated.

Organizers of international Competitions can apply to have their competition designated as 'StarClass' Competition.

## Participants

### Qualification

Skaters may be entered who have attained any one of the Qualifying Times in a Mass Start Competition. (Listed on a Members Calendar, ISU International Calendar and ISU events.)

Proof must be supplied by submitting time, date and venue of the Event.

These entries will be checked by the StarClass Coordination Group.

	500 m	1000 m	1500 m
	Mass Start	Mass Start	Mass Start
Ladies Star Class	49.2	1.42.0	2.36.8
Ladies Jun A EuroStar	50.7	1.42.1	2.36.8
Ladies Jun B EuroStar	53.8	1.48.4	2.46.5
Ladies Jun C EuroStar	56.5	1.53.9	2.54.8
Ladies Jun D EuroStar	59.7	2.00.2	
Men Star Class	46.3	1.34.6	2.27.5
Men Jun A EuroStar	47.0	1.39.3	2.30.6
Men Jun B EuroStar	51.0	1.45.4	2.39.9
Men Jun C EuroStar	53.5	1.50.7	2.47.9
Men Jun D EuroStar	56.5	1.56.9	

Only times skated within the current or the preceding season will be accepted as qualifying time.

Only senior skaters or juniors who have achieved the time limit for the StarClass category have the option to participate in either the StarClass or Junior age categories. This decision can only be taken at the beginning of the season, but it is strongly recommended for Juniors to skate in their Age category.

Juniors who have not achieved the StarClass Time Limit can only skate in the category to which they, on the basis of their age belong, provided the respective time limit has been complied with.

Only participants in the A, B, C and D Junior categories are able to qualify for the Junior Europa Cup Final.

### **Entry**

Entries in the 'StarClass' Competitions can only be made by the Member of the International Skating Union.

With the approval of the respective Member the Clubs belonging to this Member may be active in this matter and take care of the actual administrative process to make the entries.

The athletes will always participate under the name of their club. Athletes entered as Member of a National Team will be recorded with the text '(NT)' behind their family name to confirm their status.

The entry must fulfil all requirements of the ISU Regulations (insurance, minimum age to compete in a senior competition, etc.)

Organizers should consult with the Coordination Group (Mr. Ian Gooch) to determine the eligibility of entered athletes to participate in the StarClass category. A copy of the Preliminary Entries including the name of the skater, club, date of birth, qualifying time, distance, date and which competition it was achieved at, according to the StarClass Rules, should be sent by email to [iangooch@btinternet.com](mailto:iangooch@btinternet.com)

Preliminary Entries must be received 30 days before the first day of the Competition. Final Entries must be received 5 days before the first day of the Competition. Final Entries must contain a financial statement by the respective Club/ISU Member.

All entries are made via [www.ShortTrackOnline.info](http://www.ShortTrackOnline.info)

### **Officials**

The Officials must all be on the ISU List of Officials for international Competitions and at least 2 Officials must be on one of the 3 Lists for Championships Officials. Preferably two but at least one of the Referees must be of foreign nationality.

## Expenses

The costs of travel, board and lodging of participants are at the expense of the Club/ISU Member to which the participant belongs.

Organizers will offer/announce accommodation (bed and breakfast) for maximum 50 euro pppn.

An Entrance Fee of 10 euro must be paid to the Organizers for each accredited person, e.g. for every athlete and for every coach/team leader, if there is more than one coach/teamleader. The payment should be made in advance together with the entry. For entries with more than 10 skaters the payment must be in advance. A confirmation of the entry and the payment will be sent immediately by the organizers.

The costs of travel, board and lodging of officials are the responsibility of the organizer and depending on local circumstances can be paid completely or partially.

## Conditions of Contest

### StarClass

The StarClass Competitions are held over the following distances.

StarClass & Seniors 500, 1000 and 1500 m

Junior A,B,C 500, 1000 and 1500 m

Junior D 500, 800 and 1000 m

The program of each competition shall include ALL 3 distances which must be skated according to the All-Final System. For the Overall Classification points (Final Points) are only awarded in the Final 'A'. The Distance Classification and the Overall Classification will be made according to ISU Regulations.

### All Final System

A graphical explanation of the All-Finals-System is the best way to explain this principle. Based on the participation the All Final System will be adopted for each category and distance.

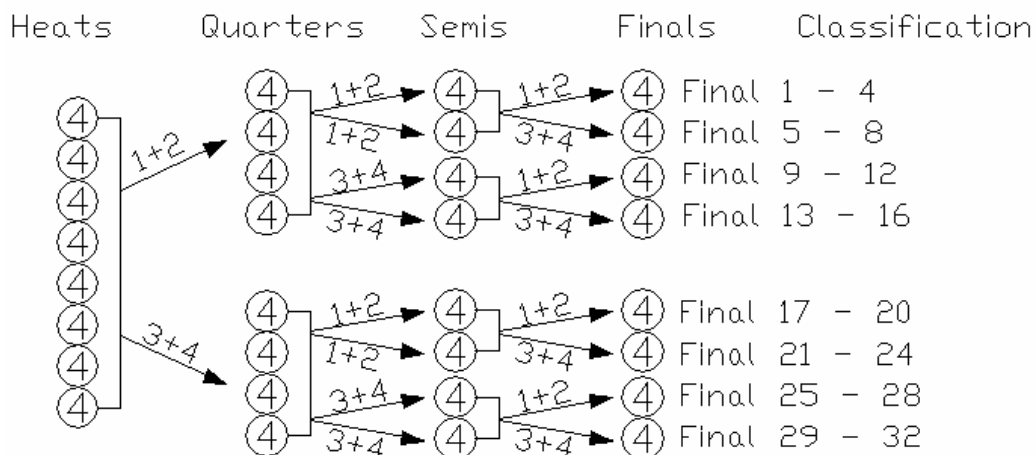

### Seeding Procedure

For the first round of the first distance the participants with a ranking in the StarClass Classifications will be seeded first according to this ranking.

Then the skaters will be seeded on the basis of the personal best time supplied with the Final Entries.

For Juniors A,B,C and D categories the first round of the first distance the participants will be seeded on the best 500m supplied with the final entries.

All other qualifying rounds the Seeding Procedure for the Top Level Races of the All Finals System shall be in accordance with I.S.U. Rule 296. The Competitors Steward will make up the races of the Lower Level Races of the All Final System as much as possible in conformity with I.S.U. Rule 296.

## **Number of Skaters per Race**

The maximum number of skaters in quarter finals, semi-finals and finals is limited according to I.S.U. Rule 282, paragraph 2 for the Top Level Races of the All Finals System only. In all other Races the Number of Skaters may be higher depending on the number of Entries.

If there are 2 skaters to qualify for the lowest Final then this Final will be skated as normal. If there is 1 skater to qualify for the lowest final then this final will not be skated but the respective Ranking will be awarded.

## **Disqualifications**

Due to the All Final Systems disqualifications are implemented differently. A skater being disqualified in a qualifying round will be allowed to skate in the next round, but on a level one stage lower than if she/he would have finished last in her/his race.

At the same moment, the best skater from that lower level (i.e. the heat-winner with the best time) is promoted to the higher level replacing the disqualified skater.

Disqualification in a final: the ranking in the Distance Classification will be equivalent to the first place in the next lower final.

This additional conditions towards disqualifications does not apply in the case of a yellow card.

## **Classification and Points scoring**

Each StarClass Competition is concluded with an Overall Classification.

On the basis of the Overall Classification the participants are awarded points for the StarClass Overall Ranking. These points and all related procedures to determine the Overall Ranking are equal to the points and procedures for World Cup competitions. See the respective ISU Communication. (1st = 1000 points, 2nd place is 80 % of first place, 3rd place is 80% of 2nd place, etc).

Skaters that were entered but did not start will not receive any points.

## **Doping Control**

Any Doping Control will be held only according to the Regulations of the International Skating Union and, if applicable, to the laws of the host country.

## **Results**

All results are published automatically on [www.ShortTrackOnline.info](http://www.ShortTrackOnline.info). Due to the cooperation with the Danubia Series the results will also be submitted to the website of the Danubia Series [to be advised](#)

## **Organisation**

The Organisers of International Competitions including the StarClass Category are expected to do their utmost to prepare a high level Competition. In this respect it is expected that :-

In due time before the Competition a good Press Release is distributed to Local Press and Media

The Competition uses the StarClass Logo

That some form of sponsoring is obtained

The Results are sent to the Press on each day of the Competition

An Awards Ceremony is held according to ISU Procedures only for the places 1 –2 –3 of the Overall Classification. Skaters should be on the platform in the Official dress of club or country (warm-up uniform), and not in jeans!

An Information booklet is available for spectators.

Information is being sent to Local Schools duly before the Competition

At least one protocol for each participating club is made available.

The results are published on the Internet

Opening Ceremony is held with the national anthem of organizers.

## **Coordination**

### **Coordination Group**

In order to coordinate the activities of the Organisers of 'StarClass' Competitions and to decide on unforeseen matter arising in between European Fixture Meetings, a Coordination Group is appointed annually at the European Fixture Meeting.

Further a group, consisting of representatives of West and East Europe will observe and guide the Qualifying and Invitation process for the final.

## **Communication**

Each Organiser of a 'StarClass' Competition will designate a liaison person who will be the first contact for the Coordination Group. Similarly each Member may also designate a liaison person. All Communication will preferably take place by email.

## **Danubia Series**

In the eastern part of Europe a similar series of Competitions are held under the name Danubia Series.

## **StarClass/Danubia Final**

From both the StarClass and the Danubia Series 10 skaters in each category will be invited to the Europe Cup Final.

Qualification to the Final Competition will be individually. That is only the named skater can qualify for the Final Competition, through the relevant series in their home area, as designated by the coordination groups of both series. If he/she is not able to participate in the Final Competition then the next skater in the classification will qualify. (To qualify a skater has to compete in a minimum of 2 StarClass Competitions). The qualification will be the best 2 results from any of the 4 StarClass Competitions). The final will be held after the last StarClass Competition. There will be a limit of 4 skaters from any one country from the final classification until the 10 places are filled per category.

An entry fee for the final should be no more than 15 Euros per skater, unless agreed at the Annual European Calendar Meeting

	Ladies		Men	
	East	West	East	West
Junior A	10	10	10	10
Junior B	10	10	10	10
Junior C	10	10	10	10
Junior D	10	10	10	10

## **Hotel Costs**

For the StarClass/Danubia Series Final the costs of Board and Lodging will be supplemented by the Organisers, provided the ISU Development is supporting the competition.

The costs of Board and Lodging at the Competitions of the Series are the responsibility of the participants. Organisers are required to announce various possibilities for board and lodging close to the competition site. The costs of Board and Lodging should not exceed the amount of 50 euros per person per night.

## **ISU Development Program**

The ISU Members in the mentioned parts of Europe will be asked to officially confirm the interest and support for this Development program for Junior Speed Skaters.

Organisers of the Competitions in the Series "StarClass" and "Danubia" will submit applications for support in accordance with Communication No 1434 to the Development Coordinator. The respective Coordination Groups will assist in preparing these applications.

## Season 2008/2009

### Competitions

During the European Fixture Meeting held in Bratislava, Slovak Rep, on 3<sup>rd</sup> May 2008 the following competitions have been designated as ' StarClass Competitions

Date	Category	Venue
*03 to 05 October 2008	S,A,B,C,D	Bolzano
*04 to 06 November 2008	S,A,B,C,D	Reims
*12 to 14 December 2008	S,A,B,C,D	Dresden
*23 to 25 January 2009	S,A,B,C,D	Leeuwarden
27 <sup>th</sup> February to 01st March 2009	StarClass/Danubia Series final	Bormio Italy

**NOTE** \* These are the qualifying events for the **StarClass/Danubia Final**

### Coordination Group

Star Class	Europa Cup Final	Danubia
Ian Gooch Daan Brand Elena Comolo Reinier Oostheim	Stuart Horsepool Istvan Darazs Reinier Oostheim Stoytcho G. Stoytchev	Istvan Darazs

Note: Any changes to the ISU Rules and Regulations mentioned in the above will be applied as and when changes are notified to members.

## **DRAFT ANNOUNCEMENT FOR ALL STAR CLASS COMPETITIONS**

The <Official Name of the ISU Member> and <Official Name of the Organising Club> have the honor and pleasure to announce that the <Name of the Competition> will be held on <Dates of the Competition> at <Name of Ice Rink> <Address of Ice Rink> in accordance with the 2008 Regulations of the International Skating Union, the 'StarClass Rules Regulations 2008/2009' and the conditions included in this Announcement.

### ***Entries***

Entries can be made by the Club of the respective athlete.

or

by the Member of the International Skating Union

In the case of an unmanageable number of entries reductions can be made by the organisers together with the Coordination Group. In this respect the total number of skaters in all categories per club may be limited and/or the number of Clubs may be limited. Principles like global representation, regional representation and first come, first serve shall be applied.

### ***Preliminary Entry***

The Preliminary Entry specifying

- Number of athletes in each category
- Date and Time of Departure and Arrival
- Number of accompanying Officials
- Provisional names

must be submitted by <30 days before the first day of the competition> and are preferably made via [www.ShortTrackOnline.Info](http://www.ShortTrackOnline.Info)

### ***Final Entry***

The Final Entry specifying/confirming

- Number of athletes in each category
- Date and Time of Departure and Arrival
- Number of accompanying Officials
- Names of the Athletes
- Names of the accompanying Officials

must be submitted at the latest <5days before the first day of the competition> and should preferably made via <http://www.shorttrackonline.info/>

All Entries must be accompanied of sufficient documentation of the performances in Mass Start Competitions and all requirements of the ISU Regulations must be fulfilled. (insurance, minimum age to compete in a senior competition, etc.)

**ALL TEAMLEADERS are very urgently requested to inform the Organisers of any changes upon departure from their home-town, at the very latest.**

### ***Entry Fee***

An Entrance Fee of no more than 10 euros must be paid to the Organisers for each accredited person, e.g. for every athlete and for every coach/team leader. Per Club one coach/team leader does not have to pay the Entrance Fee.

## Conditions of Contest

The Qualifying Schedule on each distance shall be based on an "All Finals System" in all categories. The All Final System is used in order to guarantee a minimum number of races to all participants. The organisers reserve the right to change the programme due to unforeseen circumstances.

## Categories

StarClass	Ladies and Men	(Senior and Junior A)			
EuroStar Junior A	Ladies and Men	from	01-07-19##	to	30-06-19##
EuroStar Junior B	Ladies and Men	from	01-07-19##	to	30-06-19##
EuroStar Junior C	Ladies and Men	from	01-07-19##	to	30-06-19##
EuroStar Junior D	Ladies and Men	from	01-07-19##	to	30-06-19##

The time limit to be entitled to start in the StarClass category and the Junior categories is listed in the Regulations for StarClass Competitions.

## Distances

Individual ;

StarClass	1500m	500m	1000m
Senior	1500m	500m	1000m
Junior A	1500m	500m	1000m
Junior B	1500m	500m	1000m
Junior C	1500m	500m	1000m
Junior D	1000m	500m	800m

Relay races \*\*);

StarClass Ladies	3000m	***)
StarClass Men	5000m	***)
Junior A-B-C-D Ladies	2000m.	(3 athletes) ***)
Junior A-B-C-D Men	2000m.	(3 athletes) ***)

\*\*) The relays will be skated only if there is enough time;

\*\*\*) Mixed club relay teams are not allowed.

## General Programme

Friday, xx xxxx	9.00 a.m.	Warm up
	10.00 a.m.	Competition
Saturday, xxxx	10.00 a.m.	Warm up
	11.00 a.m.	Competition
Saturday, xxxxx	2:00 p.m.	Warm up
	3.00 p.m.	Competition
Sunday, xxxxx	8.00 a.m.	Warm up
	9.00 a.m.	Competition
	2.00 p.m.	Scheduled end time of the Competition

## Board and Lodging

The participating teams are responsible for their own meals and accommodation. The Organizing Committee can offer/announce accommodation at the price of EUR xx,00 (double room) per day per person

## Track

The track is an artificial refrigerated indoor ice surface with the measures of 30x60 meters, protective padding will cover the boards. The standard track 111,12 meters to the lap with measured curves of 8,50 meters and there will be 7 markers used to establish the curve. The length of the straight is 28,85m. Besides the original track there will be 4 tracks set up to preserve good ice conditions. For all tracks one finish line will be used.

### ***Award of Prizes***

Prize for the first - second and third classed in the final results for each category - ladies and men.  
During award ceremonies, the skaters should be in club or National track suits.

### ***Medical Assistance***

Doctor and paramedical personnel will be present at the competition days. An ambulance will be on standby in case of need.

### ***Medical Insurance***

It is the sole responsibility of each Member, on behalf of its participating clubs, to ensure or provide medical and accident insurance for their athletes. Proof of such shall be requested by the Organising Committee. See I.S.U. Rule 119.

### ***Liability***

In accordance with I.S.U. Rule 119, the Organising Committee assumes no responsibility with respect to medical, bodily or personal injury or property loss or damage sustained or caused in connection with this Competition.

### ***Address Organising Committee***

Please send inquiries and entries to:

<Name of the Secretary of the Organising Committee>

<Address>

<Telephone>

<Mobilphone>

<Fax>

<Email>

<Name of the Bank, IBAN and SWIFT Code>

NEXT PAGES MAY BE USED FOR USEFULL INFORMATION:

How to reach.....

Hotel info.....